

4-20mA Current Loop Primer

Introduction

This application note's primary goal is to provide an easy-to-understand primer for users who are not familiar with 4-20mA current-loops and their applications. Some of the many topics discussed include: why, and where, 4-20mA current loops are used; the functions of the four components found in a typical application; the electrical terminology and basic theory needed to understand current loop operation. Users looking for product-specific information and/or typical wiring diagrams for DATEL's 4-20mA loop- and locally-powered process monitors are referred to DMS Application Note 21, titled "Transmitter Types and Loop Configurations."

Despite the fact that the currents (4-20mA) and voltages (+12 to +24V) present in a typical current loop application are relatively low, please keep in mind that all local and national wiring codes, along with any applicable safety regulations, must be observed. Also, this application note is intended to be used as a supplement to all pertinent equipment-manufacturers' published data sheets, including the sensor/transducer, the transmitter, the loop power supply, and the display instrumentation.

Why Use a Current Loop?

The 4-20mA current loop shown in Figure 1 is a common method of transmitting sensor information in many industrial process-monitoring applications. A sensor is a device used to measure physical parameters such as temperature, pressure, speed, liquid flow rates, etc. Transmitting sensor information via a

current loop is particularly useful when the information has to be sent to a remote location over long distances (1000 feet, or more). The loop's operation is straightforward: a sensor's output voltage is first converted to a proportional current, with 4mA normally representing the sensor's zero-level output, and 20mA representing the sensor's full-scale output. Then, a receiver at the remote end converts the 4-20mA current back into a voltage which in turn can be further processed by a computer or display module.

However, transmitting a sensor's output as a voltage over long distances has several drawbacks. Unless very high input-impedance devices are used, transmitting voltages over long distances produces correspondingly lower voltages at the receiving end due to wiring and interconnect resistances. However, high-impedance instruments can be sensitive to noise pickup since the lengthy signal-carrying wires often run in close proximity to other electrically-noisy system wiring. Shielded wires can be used to minimize noise pickup, but their high cost may be prohibitive when long distances are involved.

Sending a current over long distances produces voltage losses proportional to the wiring's length. However, these voltage losses—also known as "loop drops"—do not reduce the 4-20mA current as long as the transmitter and loop supply can compensate for these drops. The magnitude of the current in the loop is not affected by voltage drops in the system wiring since all of the current (i.e., electrons) originating at the negative (-) terminal of the loop power supply has to return back to its positive (+) terminal—fortunately, electrons cannot easily jump out of wires!

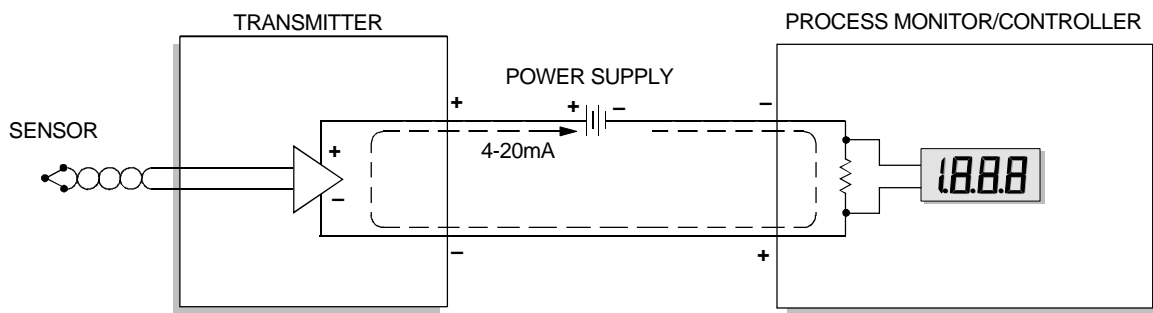

Figure 1. Typical Components Used in a Loop Powered Application

Current Loop Components

A typical 4-20mA current-loop circuit is made up of four individual elements: a sensor/transducer; a voltage-to-current converter (commonly referred to as a transmitter and/or signal conditioner); a loop power supply; and a receiver/monitor. In loop powered applications, all four elements are connected in a closed, series-circuit, loop configuration (see Figure 1).

Sensors provide an output voltage whose value represents the physical parameter being measured. (For example, a thermocouple is a type of sensor which provides a very low-level output voltage that is proportional to its ambient temperature.) The transmitter amplifies and conditions the sensor's output, and then converts this voltage to a proportional 4-20mA dc-current that circulates within the closed series-loop. The receiver/monitor, normally a subsection of a panel meter or data acquisition system, converts the 4-20mA current back into a voltage which can be further processed and/or displayed.

The loop power-supply generally provides all operating power to the transmitter and receiver, and any other loop components that require a well-regulated dc voltage. In loop-powered applications, the power supply's internal elements also furnish a path for closing the series loop. +24V is still the most widely used power supply voltage in 4-20mA process monitoring applications. This is due to the fact that +24V is also used to power many other instruments and electromechanical components commonly found in industrial environments. Lower supply voltages, such as +12V, are also popular since they are used in computer-based systems.

Loop Drops

One of a process monitor's most important specifications—be it a loop-powered or locally powered device—is the total resistance (or "burden") it presents to the transmitter's output driver. Most transmitter's data sheets specify the maximum loop resistance the transmitter can drive while still providing a full-scale 20mA output (the worst-case level with regards to loop burden).

Ohm's Law states that the voltage drop developed across a current-carrying resistor can be found by multiplying the resistor's value by the current passing through it. Stated in mathematical terms:

$$E = I \times R$$

where E is the voltage drop in volts, I is the current through the resistor in amperes, and R is the resistor's value in Ohms (the 'Ω' symbol is commonly used to represent Ohms).

The sum of the voltage drops around a series loop has to be equal to the supply voltage. For example, when a loop-powered application is powered from a 24V power source, the sum of all the voltage drops around the series loop has to also equal 24V. Every component through which the 4-20mA loop current passes develops a maximum voltage drop equal to that component's resistance multiplied by 0.020 Amperes (20mA). For example, referring to Figure 2 the DMS-20PC-4/20S's 250Ω resistance yields a maximum loop drop of :

$$250\Omega \times 0.020A = 5.0V$$

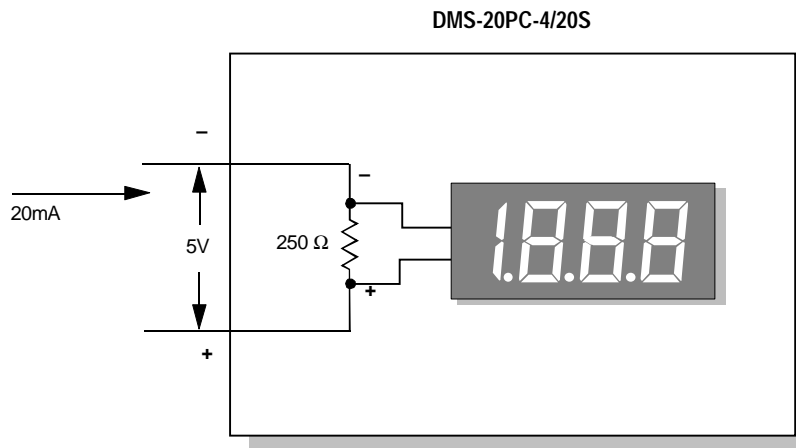

$$\text{Loop Drop} = 250 \Omega \times .020A = 5V$$

Figure 2. Calculating Loop Drops

Transmitter Ratings

With the above loop-drop theory in mind, and assuming a +24V loop-powered application in which the transmitter's minimum operating voltage is 8V, and the process monitor drops only 4V, a logical question which arises is what happens to the "extra" 12V? The extra 12V has to be dropped entirely by the transmitter since most process monitors have purely resistive inputs combined with zener diodes that limit their maximum voltage drop.

Transmitters usually state both minimum and maximum operating voltages. The minimum voltage is that which is required to ensure proper transmitter operation, while the maximum voltage is determined by its maximum rated power-dissipation, as well as by its semiconductors' breakdown ratings. A transmitter's power dissipation can be determined by multiplying its loop drop by the highest anticipated output current, usually, but not always, 20mA. For example, if a transmitter drops 30V at an overrange output level of 30mA, its power dissipation is:

$$30V \times 0.030A = 0.9 \text{ watts}$$

Wiring Resistance

Because copper wires exhibit a dc-resistance directly proportional to their length and gauge (diameter), this application note would not be complete without discussing the important topic of wiring — specifically the effects wiring resistance has on overall system performance.

Applications in which two or more loop-monitoring devices are connected over very long, 2-way wiring distances (1000-2000 feet) normally use +24V supplies because many transmitters require a minimum 8V-supply for proper operation. When this 8-volt minimum is added to the typical 3-4 volts dropped by each process monitor

and the 2-4 volts dropped in the system wiring and interconnects, the required minimum supply voltage can easily exceed 16V. The following worked-out example will illustrate these important concepts.

The voltage drop developed along a given length of wire is found by multiplying the wire's total resistance by the current passing through it. The wire's total resistance is found by looking up its resistance (usually expressed in Ohms per 1000 feet) in a wire specifications table. Referring to Figure 3 if a transmitter's output is delivered to a remote process monitor using 2000 feet (660 meters) of 26-gauge, solid copper wire having a resistance of 40.8Ω per 1000 feet, the one-way voltage dropped by the wire when the transmitter's output is 20mA is equal to:

$$E = 0.020 \text{ Amperes} \times [2000 \text{ feet} \times (40.8\Omega / 1000 \text{ feet})]$$

$$E = 0.020A \times 81.6\Omega = 1.63V$$

However, the current must travel 2000 feet down to the process monitor and another 2000 feet back to the transmitter's "+" output terminal, for a total of 4000 feet. As noted above, 26-gauge wire has a resistance of 40.8Ω per 1000 feet, yielding a total loop resistance (R) equal to 4000 feet x (40.8Ω / 1000 feet) = 163.2Ω. The total voltage dropped over the 4000 feet of wiring is therefore:

$$E = 0.020A \times 163.2\Omega$$

$$E = 3.27V.$$

Looking down the loop towards the remote process monitor, the transmitter sees the sum of the 3.27V wire drop and the 5.0V process-monitor drop, for a total loop-drop of 8.27V. If the transmitter itself requires a minimum of 8V (this is also considered a voltage drop) for proper operation, the lowest power supply voltage required for the system shown in Figure 3 is 16.3V.

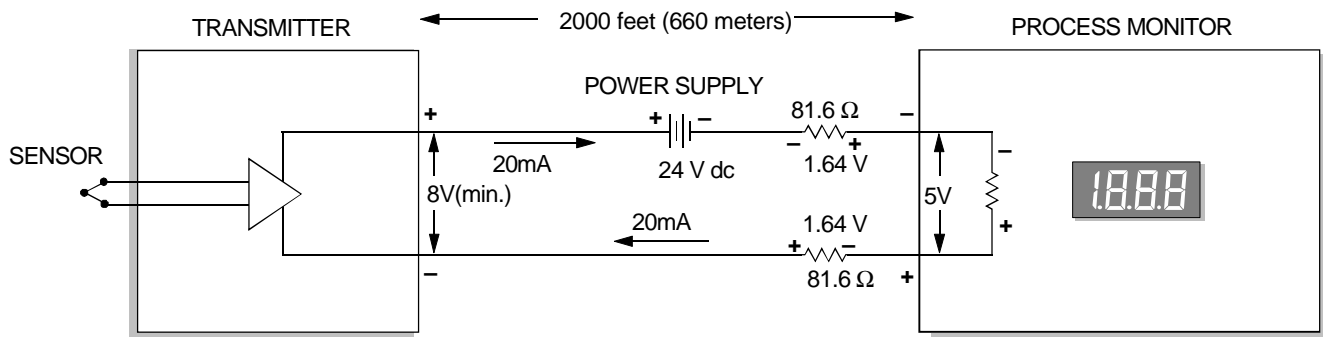

Figure 3. Wiring Resistance Effects